

sez A-A

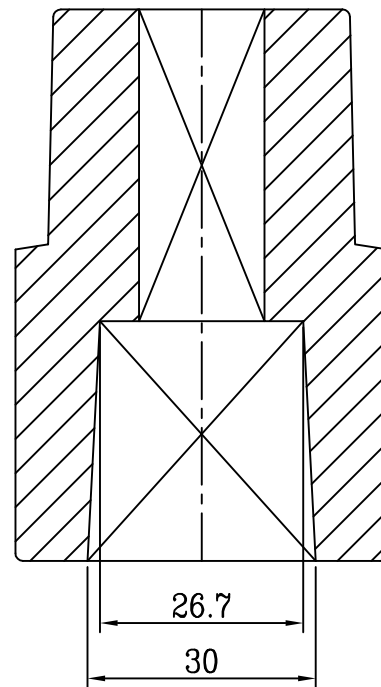
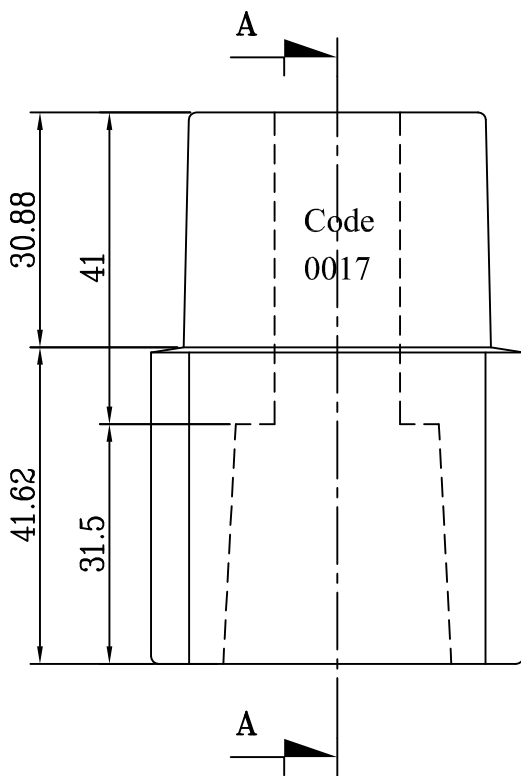

TOLLERANZE / TOLERANCES									
LUNGHEZZA	ANGOLI	SMUSSI	RAGGI						
LENGTH	ANGLES	BEVELS	RADIUS	INDICE	NATURA DELLA MODIFICA		DATA	FIRMA	
UNI - ISO 27168 m				DENOMINAZIONE / DENOMINATION					
FORI/ HOLES H13		ALBERI/ SHAFTS H13		CAPPELOTTO QUADRO PER CH0036					
SCALA / SCALE 1:1 SU (A4)		MATERIALE / MATERIAL EN-GJL-200 UNI EN 1561-98			DISEGNATO/ DRAWN DATA S BR 13/12/2012		FIRMA		
 ZIGGIOTTO & C. RONCO ALL'ADIGE VERONA - ITALIA				DUREZZA / HARDNESS		PESO / WEIGHT 0.655 Kg		VERIFICATO/CONTROLLED DATA	FIRMA
				RESISTENZA / STRENGTH		TRATTAMENTO/TREATMENT		CODICE / CODE sch-ART19_CH0036-QUADRA REV.0	

A termini di legge é vietato l'uso, la divulgazione e la riproduzione senza l'autorizzazione scritta della ZIGGIOTTO & C.