



ZIGGIOTTO®
GARDA EN
Pillar dry hydrant
EN 14384
Type "C"

**MAINTENANCE,
INSTALLATION AND
FUNCTION MANUAL**

CSICERT



UNI EN ISO 9001



SINCERT

FISA



"GARDA EN" PILLAR DRY HYDRANT EN 14384 Tipo C

ZIGGIOTTO

General Description

Pillar dry hydrant conforming to the normative "UNI EN 14384".

Classified as type "C", with anti-freeze drain system, pre-set break off point and automatic shut off in case of breakage to prevent water escape.

Opening and closing are possible only with apposite wrench.

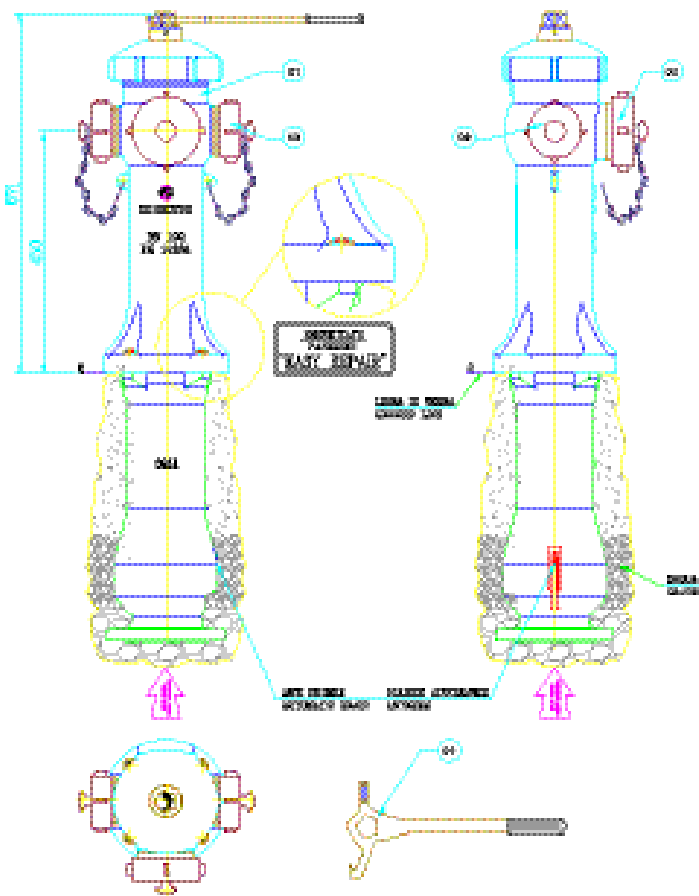

LEGEND

PILLAR DRY HYDRANT

1. NO. 2 OUTLETS DN70 COMPLETE WITH CAP AND CHAIN
2. NO. 1 OUTLET DN100 COMPLETE WITH CAP AND CHAIN

OPENING WRENCH (OPTIONAL)

CARACTERISTICS

- MAXIMUM PRESSURE : 1,6 MPa
- "ESY REPAIR" SYSTEM
- TEST PRESSURE: 2,5 MP
- ABOVE GROUND HEIGHT: 680mm
- UNDERGROUND DEPTH: AVAILABLE 500 - 700 - 1000mm
- OUTLET HEIGHT: 450 mm
- INLET FLANGE PN16 ACCORDING TO EN 1092-2 PN16
- HYDRANT BODY IN CAST IRON EN GJL 250 ACCORDING TO UNI EN 1503-3

VERNICIATURA

- ABOVE GROUND PART: EPOSSIDIC RED RAL 3000
- UNDERGROUND PART: EPOSSIDIC BLACK---



"GARDA EN" PILLAR DRY HYDRANT EN 14384 Tipo C

ZIGGIOTTO

System specifications, installation

POSITIONING

The hydrant must be positioned with the quote at 10-15 mm from the fitting flange between the red part and the black one, in order to permit the disassembly in case of repair.

It can be anchored with plain concrete in the black part.

CAUTION: in corrispondence of the anti-freeze discharge of the yhydrant and its emptying when it is closed.

CLEANING

You have to be sure of the perfect cleaning of the flange before fixing the hydrant. Check, moreover, the missing of foreing parts in the pipe.

Parts of stones, wood or other material could damage in a irreparable way the valve system and gaskets.

TYPICAL INSTALLATION

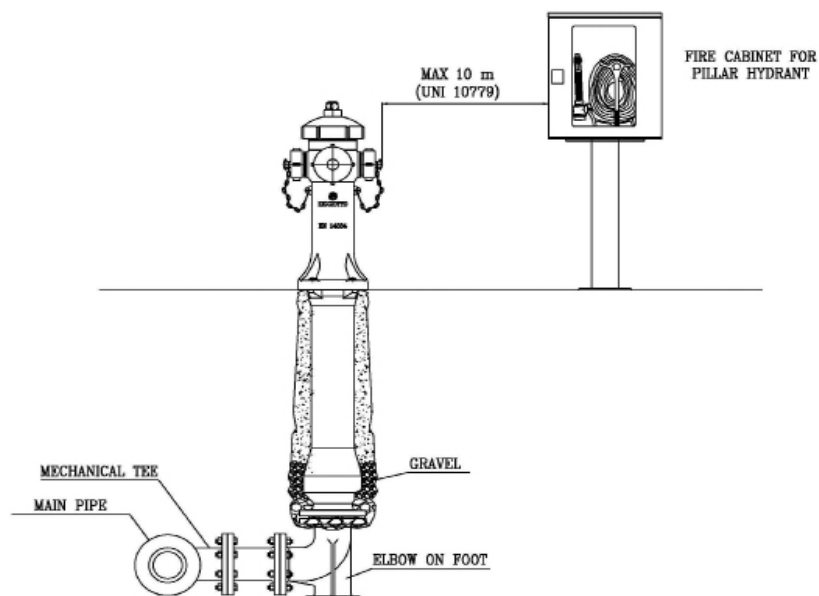

TECHNICAL CHARACTERISTIC:

Underground part must be at list
300 mm deep from ground level to
automatic drainage





"GARDA EN" PILLAR DRY HYDRANT EN 14384

Tipo C

ZIGGIOTTO

hydrant use

OPENING

The opening of the valve must be always carried out till the end. (12-13 turns). With only 2/3 turns the water fills the hydrant but the close gasket of the anti-freeze discharge can't close the hole, for this reason it can lose water.

The opening must be done in the following way:

- 2/3 "dead turns"
- opening with necessary stress in order to win the pressure (1 turn)
- 9/10 turns in order to open completely the valve and close the anti-freeze discharge.

During the hydrant, keep 1 union open in order to facilitate the defluxion of water.

CLOSING

The closing must be done without practising stress on the control shaft. The valve closes with the pressure, for this reason it is enough to lean it on its place in brass.

After the closing the water starts to go out the water finishes after 10/15 minutes.

CAUTION: instruction the personell carefully, especially during testing phase in order to avoid the excessive tight because the water goes out from the anti-freeze discharge damaging the rubber of the valve and the nut screw of the control shaft.

KEY

Use only the specific control shaft, our operating key CH0037 to avoid the practise and excessive and undsefull stress with the risk of damaging the break of the internal components of the control system.

MAINTENANCE AND TEST

The hydrants is free form the maintenance. In normal use coniditions it mustn't be oiled and ypu can't replace the o-ring.

It is advisable at last 1 test per year in order to check the correct functioning

- Open 1 outlet
- Apply a fire hose
- Open the hydrant
- Keep it open for 2/3 minutes
- close the hydrant

SECTIONING DEVICE - ONLY FOR GARDA TYPE C

In case of accidental impact the hydrante is preset for a sectioning that allows the reinstatement with the simple replacement of the semiflange in cast iron and the central articulation of the control shaft in brass. For this operation it is available a reinstatement kit called " easy repair kit" (semiflange, brass articulation, gasket and nuts). In case of the damage is greater, please contact the supplier.



"GARDA EN" PILLAR DRY HYDRANT EN 14384 Tipo C

ZIGGIOTTO

LIST:

Pos.	Description	Q.tà
1	INFERIOR BODY	1
2	CLOSURE RING FOR VALVE	1
3	SEAL VALVE	1
4	STAND VALVE FOR	1
5	PIPE AD	1
6	NUT SCREW	1
7	SCREW CLOSING HYDRANT NEW ZIG	1
8	DEVOIUS ADHESION	1
9	SCREW UNI5927	2
10	MALE PENTAGON	2
11	FEMALE PENTAGON	1
12	SUPERIOR BODY	1
13	PIPE UPPER ADR	1
14	ACTUATION CLOSING HYDRANT NEW ZIG	1
15	BUSH	1
16	O-RING	1
17	O-RING	1
18	PARALLEL PIN	4
19	O-RING	1
20	SCREW TCEI M06X30	2
21	WASHER TEFLON	2
22	SCREW TCEI	1
23	COVER FOR DRAIN HOLE	1
24	SEAL	1
25	WASHER INOX	1
26	SCREW T.E.	1
27	SCREW	4
28	AXSLE-BOXES OF BREACH	4
29	MALE PENTAGON LOWER	1

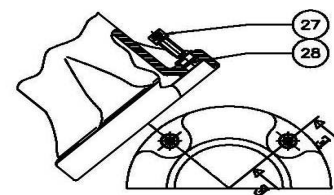
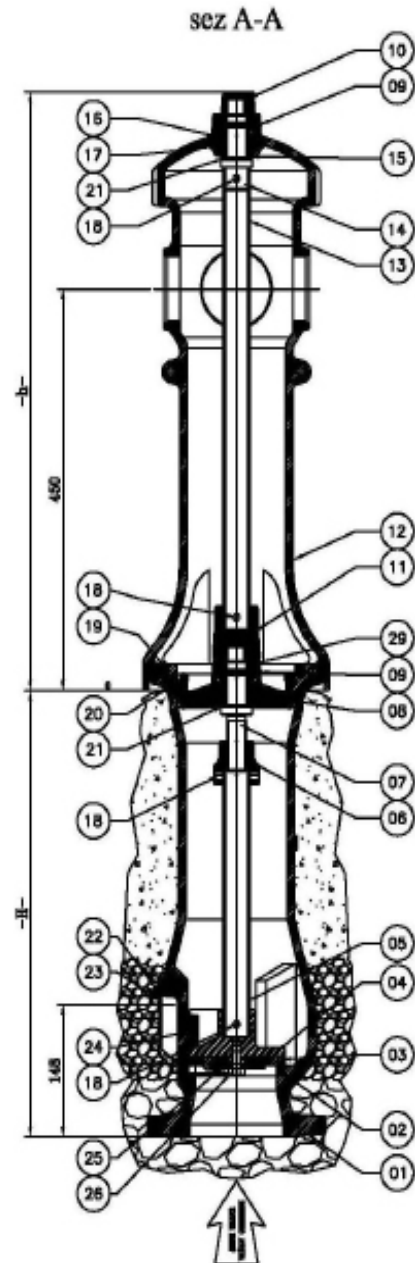

SPARE PARTS:

For eventual damages, or malfunction,
use only original spare parts available by
the supplier.

