

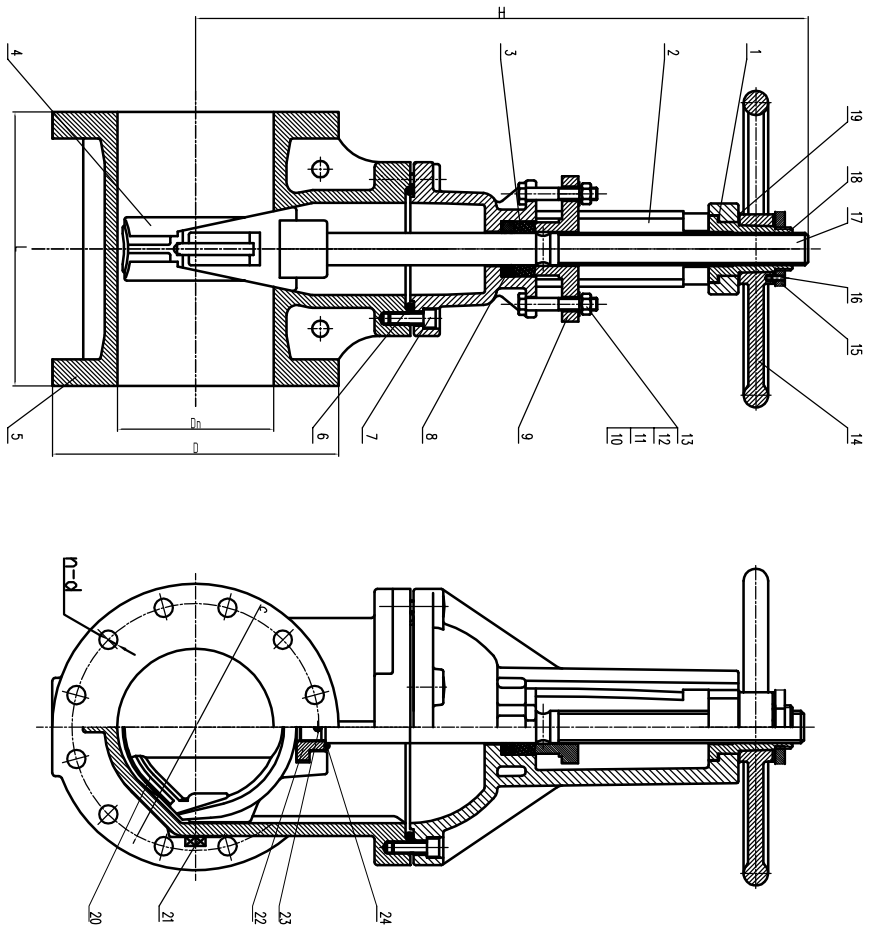

TECHNICAL SPECIFICATION
 1. DESIGN STANDARD: AWMA C515.
 2. NOMINAL PRESSURE: 300PSI.
 3. FLANGE STANDARD: ASME/ANSI B16.1 Class 125 OR ASME/ANSI B16.42 Class 150 OR BS EN1092-2 PN16 OR GB/T9113.1.
 4. FACE TO FACE STANDARD: ASME B16.10
 5. ELECTROSTATIC SPRAYING BOTH INSIDE AND OUTSIDE OF THE BODY.



DN	L	H	ØD	C	n-d
DN300	356	1031	460	410	12-Ø28
DN250	330	890	405	355	12-Ø28
DN200	292	754	340	295	12-Ø23
DN150	267	607	285	240	8-Ø23
DN125	254	547	250	210	8-Ø19
DN100	229	447	220	180	8-Ø19
DN80	203	420	200	160	8-Ø19
DN65	190	370	185	145	4-Ø19

NO	CODE	NAME	QTY	MATERIAL	REMARK
24		SEALING RING	1	EPDM	GB/T 3452.1-2005
23		PIN	1	S.S.304	GB 119.1-2000
22		MH-11ZR-NPSM-11 LIFTING NUT	1	CF8M	
21		MH-11ZR-NPS-11 PLUG	2	C95400	
20		MH-11ZR-NPS-14 SKELETON	1	DI	
19		MH-11ZR-NPSM-10 GASKET	1	C95400	
18		MH-11ZR-NPSM-09 STEM NUT	1	C95400	
17		MH-11ZR-NPSM-08 STEM	1	S.S.304	
16		LOCATING SCREW	1	S.S.304	GB/T 72-1988
15		MH-11ZR-NPSM-07 LOCK NUT	1	C95400	
14		MH-11ZR-NPSM-06 HANDWHEEL	1	DI	
13		SPRING WASHER	2	Steel	GB/T 93-1987
12		BOLT	2	Steel	GB/T 5782-2000
11		FLAT WASHER	2	Steel	GB/T 95-2002
10		NUT	2	Steel	GB/T 6170-2000
9		MH-11ZR-NPSM-05 GLAND	1	DI	
8					
7		BOLT	m	Steel	GB/T 70-2000
6		MH-11ZR-NPS-06 SEALING RING	1	EPDM	
5		MH-11ZR-NPS-05 BODY	1	DI	
4		MH-11ZR-NPS-04 DISC	1	EPDM+DI	
3		MH-11ZR-NPSM-03 PACKING	3	GRAPHITE	
2		MH-11ZR-NPSM-02 BONNET	1	DI	
1		MH-11ZR-NPSM-01 GASKET	1	C95400	

TOLLERANZE / TOLERANCES	INDICE	NATURA DELLA MODIFICA	DATA	FIRMA
LUNGHEZZA / LENGTH	SMUSI / ANGOLI			
RAGGI / RADIUS	SMUSI / ANGOLI			
UNI - ISO 27168	SMUSI / ANGOLI			
FORI / HOLES	SMUSI / ANGOLI			
H13	SMUSI / ANGOLI			
ALBERI / SHAFTS	SMUSI / ANGOLI			
H13	SMUSI / ANGOLI			
SCALA / SCALE	SMUSI / ANGOLI			
MATERIALE / MATERIAL	SMUSI / ANGOLI			
DUREZZA / HARDNESS	SMUSI / ANGOLI			
PESO / WEIGHT	SMUSI / ANGOLI			
RESISTENZA / STRENGTH	SMUSI / ANGOLI			
TREATMENT/TREATMENT	SMUSI / ANGOLI			
DISSEGNO/ DRAWING DATA	SMUSI / ANGOLI			
VM	SMUSI / ANGOLI			
28/07/2018	SMUSI / ANGOLI			
FIRMA	SMUSI / ANGOLI			

ZIGGIOTTO & C.
 RONCO ALL'ADIGE
 VERONA - ITALIA

SARACINESCA OS&Y MOD. NIAGARA

dis-Art 400 Rev.1

A termini di legge è vietato l'uso, la divulgazione e la riproduzione senza l'autorizzazione scritta della ZIGGIOTTO & C.